

DIMENSION DRAWING		No.	No.	A-20690-1
TYPE	Sewage Submersible Vortex Pump	MODEL	5OUT2.4S -52/62 5OUT2.4 -52/62	

MODEL	Approximate Weight (kg)
5OUT2.4S-52/62	13.5kg
5OUT2.4-52/62	13kg

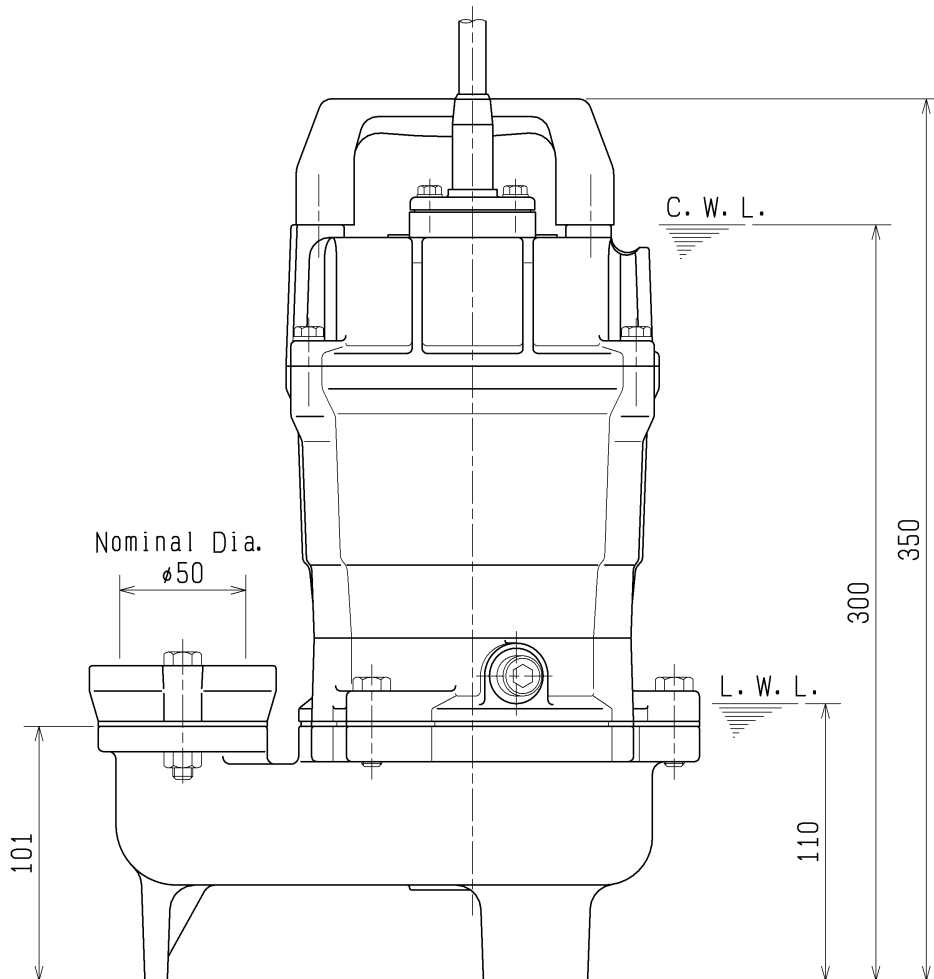
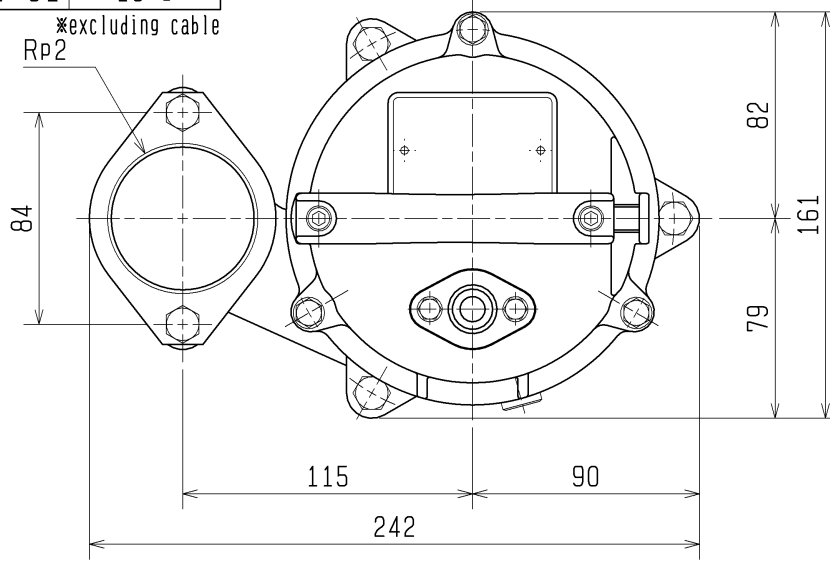

C. W. L. :Continuous running Water Level
L. W. L. :Lowest running Water Level

SECTIONAL DRAWING		No.	No.	A-20698-1
TYPE	Sewage Submersible Vortex Pump	MODEL	50UT2.4S -52/62	

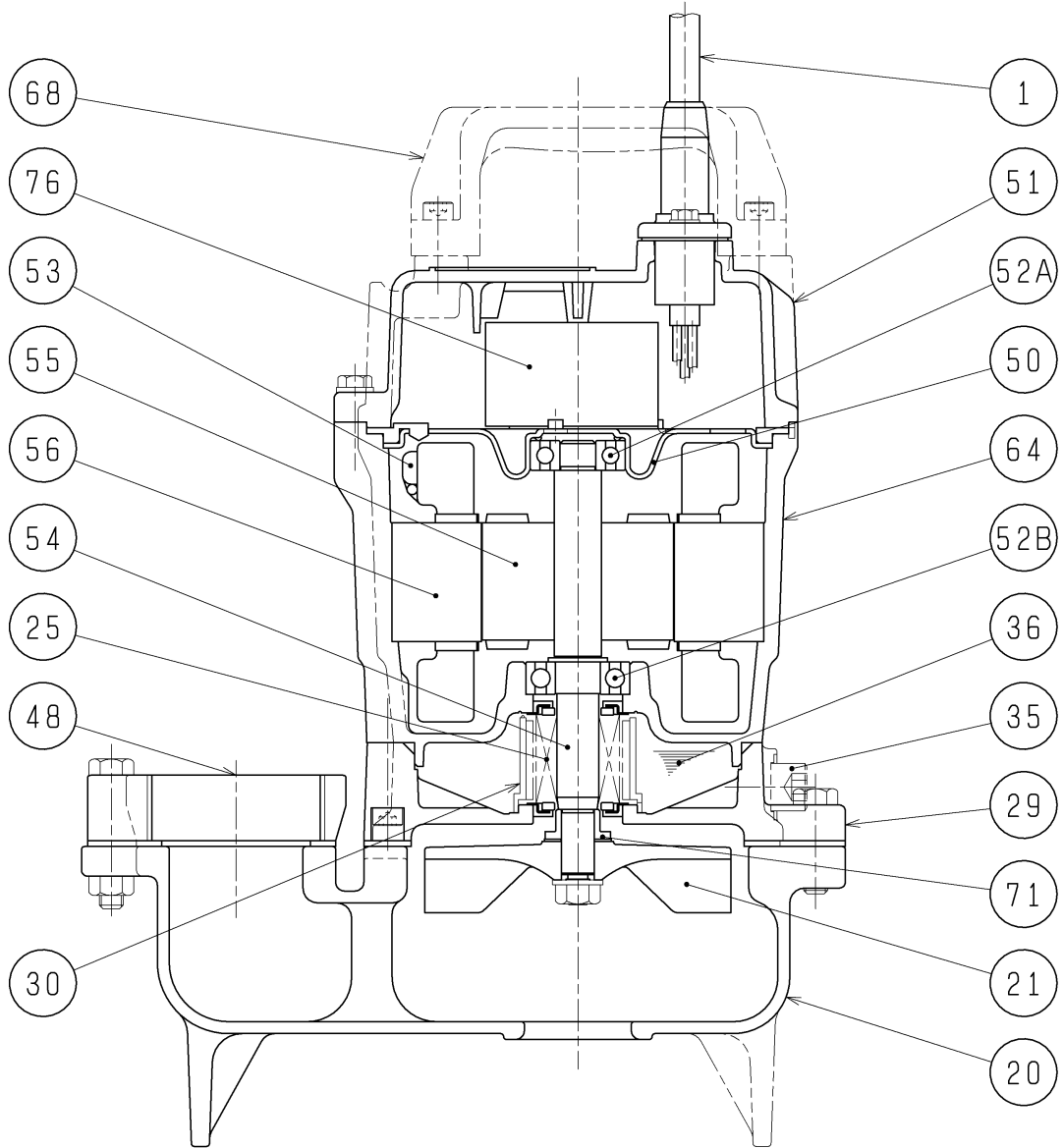

Aussie Pumps

REQ. SPECIFICATION	

No.	DESCRIPTION	Q'TY	MATERIAL / NOTE	No.	DESCRIPTION	Q'TY	MATERIAL / NOTE
1	Cable	1	PVC Sheath	52A	Upper Bearing	1	6201ZZC3
20	Pump Casing	1	Gray Iron Casting	52B	Lower Bearing	1	6202ZZC3
21	Impeller	1	Plastic W/GF	53	Motor Protector	1	
25	Mechanical Seal	1	W-14VCCA	54	Shaft	1	Stainless Steel 403
29	Oil Casing	1	Gray Iron Casting	55	Rotor	1	
30	Oil Lifter	1	Plastic	56	Stator	1	
35	Oil Plug	1	Stainless Steel 304	64	Motor Frame	1	Gray Iron Casting
36	Lubricant		Turbine Oil (ISO VG32)	68	Handle	1	Plastic
48	Screwed Flange	1	Gray Iron Casting	71	Shaft Sleeve	1	Stainless Steel 304
50	Motor Bracket	1	Steel Sheet	76	Capacitor	1	
51	Head Cover	1	Gray Iron Casting				

NO. A-20676-1

PUMP PERFORMANCE CURVES

TYPE Sewage Submersible Vortex Pump	MODEL 50UT2.4S -52	FREQUENCY 50 Hz
-------------------------------------	--------------------	-----------------

CUSTOMER'S NAME _____

EQUIPMENT TITLE _____ NO. _____

	STANDARD SPECIFICATIONS	REQUIRED SPECIFICATIONS
DISCHARGE BORE	50 mm	mm
TOTAL HEAD	MAX. 9.0 m	m
CAPACITY	MAX. 0.27 m ³ /min	m ³ /min
MOTOR OUTPUT	0.4 kW	kW
PHASE x VOLTAGE	1 ϕ x V	ϕ x V
CURRENT	A	A
POLES / REVOLUTION	2 P / S. S. 3000 min ⁻¹	P / min ⁻¹
STARTING METHOD	CAPACITOR MOTOR	
INSULATION CLASS	E	

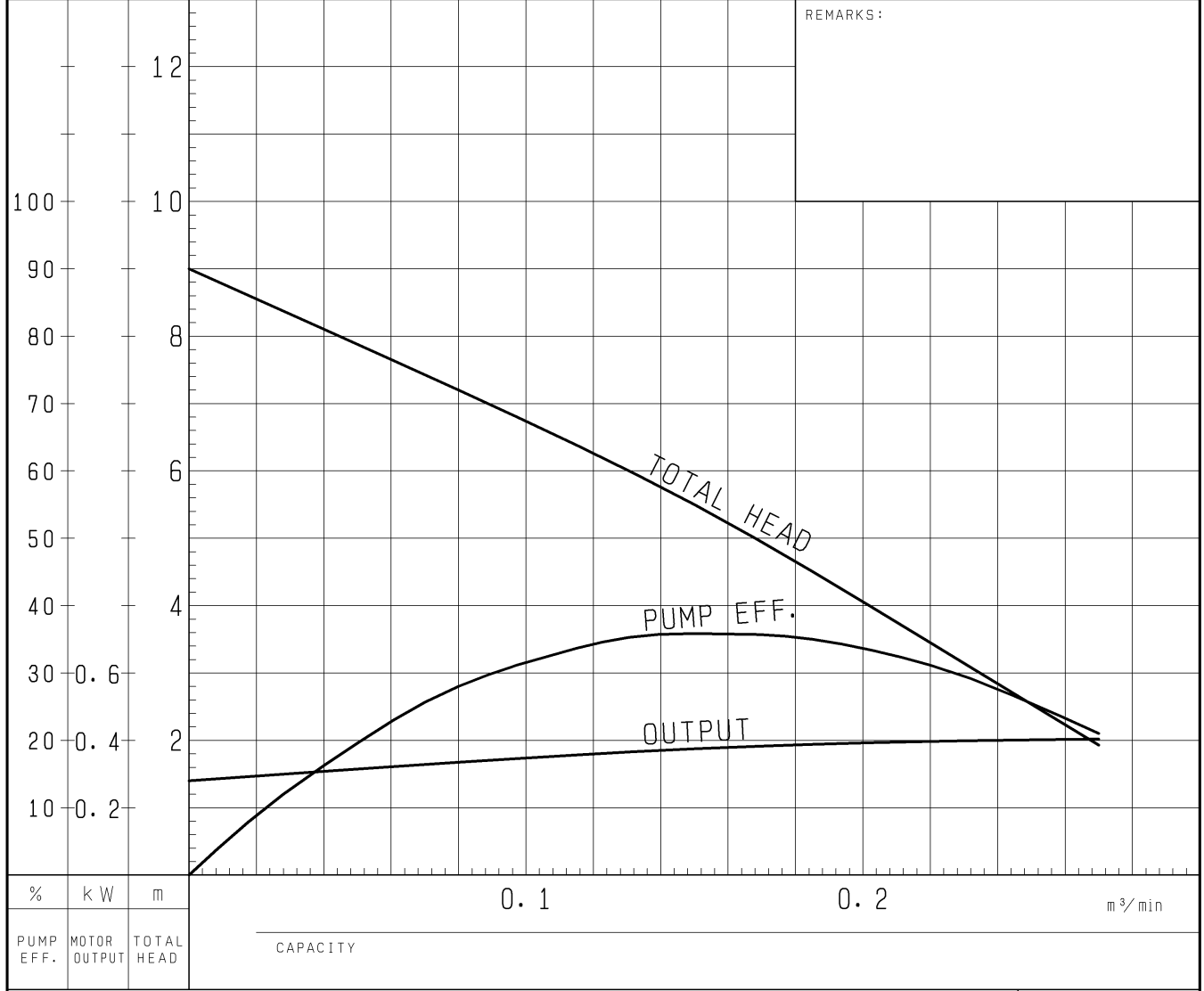

TSURUMI MFG. CO., LTD.

