

DIMENSION DRAWING		No.	No.	A-20694-1
TYPE	Sewage Submersible Vortex Pump (Automatic)	MODEL	50UTZ2.75S -52/62	

Approximate Weight (※)
16.5kg

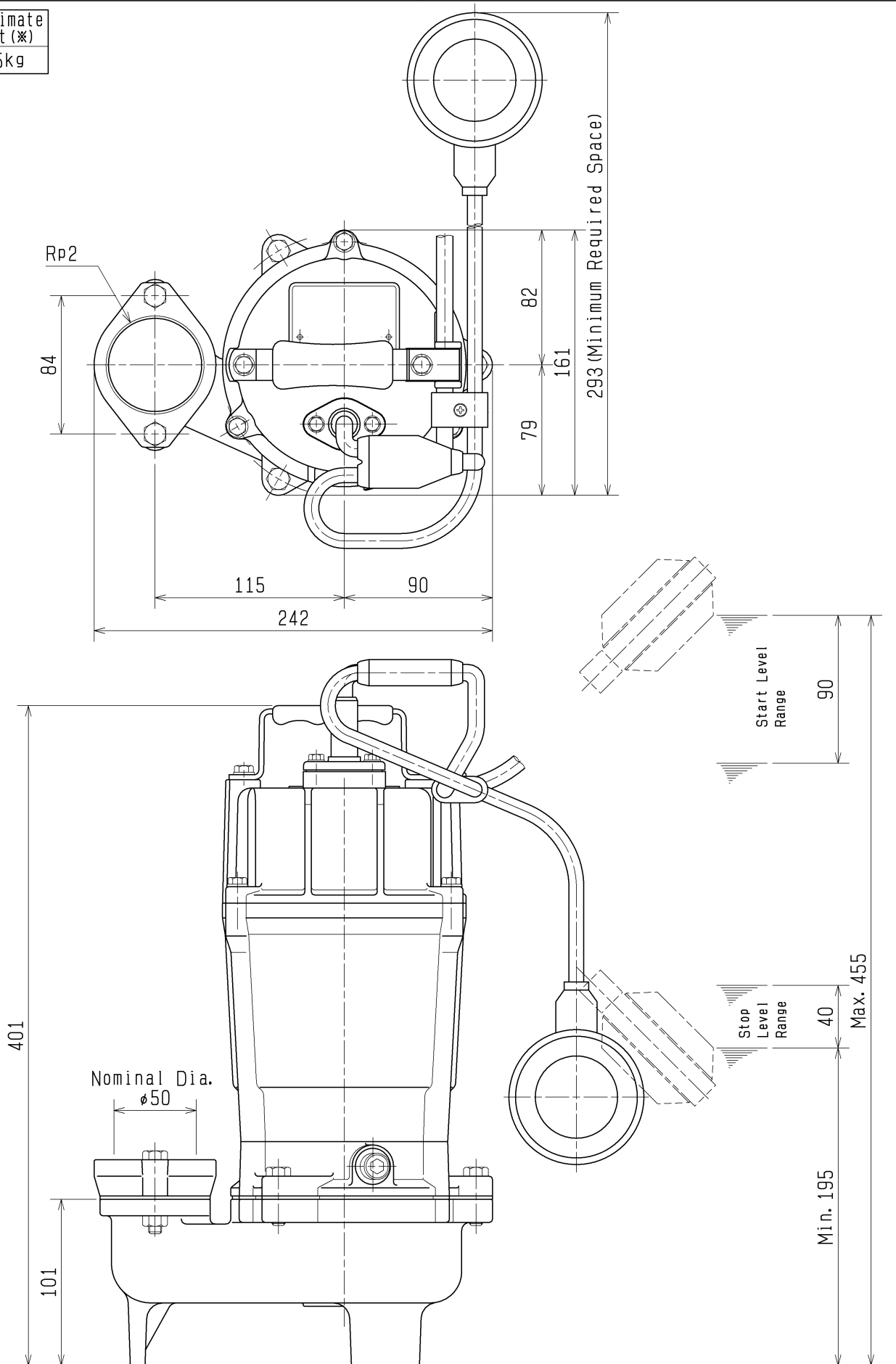

SECTIONAL DRAWING		No.	No. A-20703-1
TYPE	Submersible Vortex Sewage Pump	MODEL	50UTZ2.75S -52/62

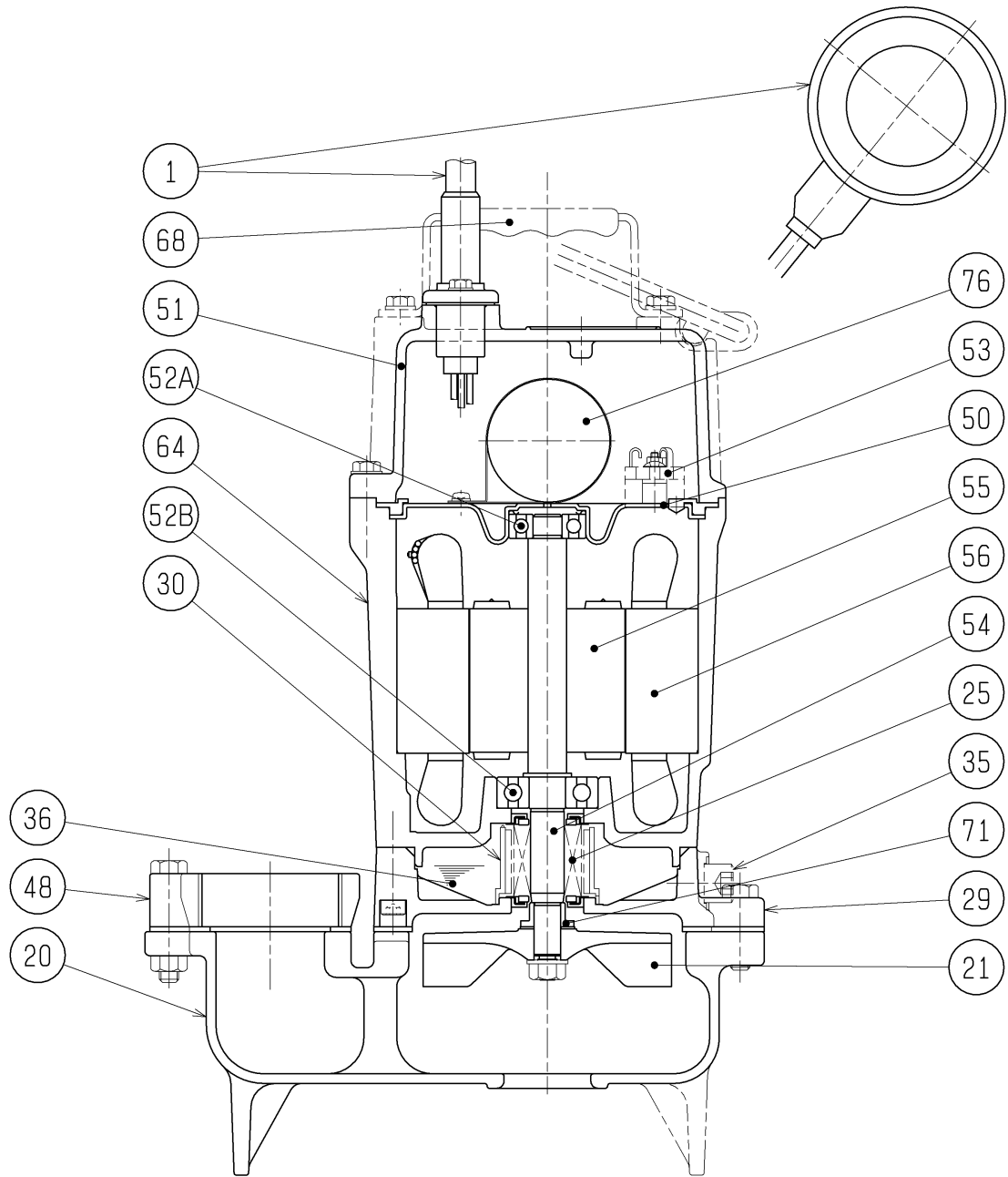

*Aussie Pumps*

REQ. SPECIFICATION

No.	DESCRIPTION	Q'TY	MATERIAL / NOTE	No.	DESCRIPTION	Q'TY	MATERIAL / NOTE
1	Cable Cable c/w Float	1	PVC Sheath	52A	Upper Bearing	1	6201ZZC3
20	Pump Casing	1	Gray Iron Casting	52B	Lower Bearing	1	6302ZZC3
21	Impeller	1	Plastic W/GF	53	Motor Protector	1	
25	Mechanical Seal	1	W-14VCCA	54	Shaft	1	Stainless Steel 403
29	Oil Casing	1	Gray Iron Casting	55	Rotor	1	
30	Oil Lifter	1	Plastic	56	Stator	1	
35	Oil Plug	1	Stainless Steel 304	64	Motor Frame	1	Gray Iron Casting
36	Lubricant		Turbine Oil (ISO VG32)	68	Handle	1	Steel Sheet & Natural Rubber
48	Screwed Flange	1	Gray Iron Casting	71	Shaft Sleeve	1	Stainless Steel 304
50	Motor Bracket	1	Steel Sheet	76	Capacitor	1	
51	Head Cover	1	Gray Iron Casting				

NO. A-20686-1

# PUMP PERFORMANCE CURVES

TYPE Sewage Submersible Vortex Pump	MODEL 5OUTZ2.75S -52	FREQUENCY 50 Hz
-------------------------------------	----------------------	-----------------

CUSTOMER'S NAME \_\_\_\_\_

EQUIPMENT TITLE \_\_\_\_\_ NO. \_\_\_\_\_

	STANDARD SPECIFICATIONS	REQUIRED SPECIFICATIONS
DISCHARGE BORE	50 mm	mm
TOTAL HEAD	MAX. 12.5 m	m
CAPACITY	MAX. 0.44 m <sup>3</sup> /min	m <sup>3</sup> /min
MOTOR OUTPUT	0.75 kW	kW
PHASE x VOLTAGE	1 $\phi$ x V	$\phi$ x V
CURRENT	A	A
POLES / REVOLUTION	2 P / S. S. 3000 min <sup>-1</sup>	P / min <sup>-1</sup>
STARTING METHOD	CAPACITOR MOTOR	
INSULATION CLASS	E	

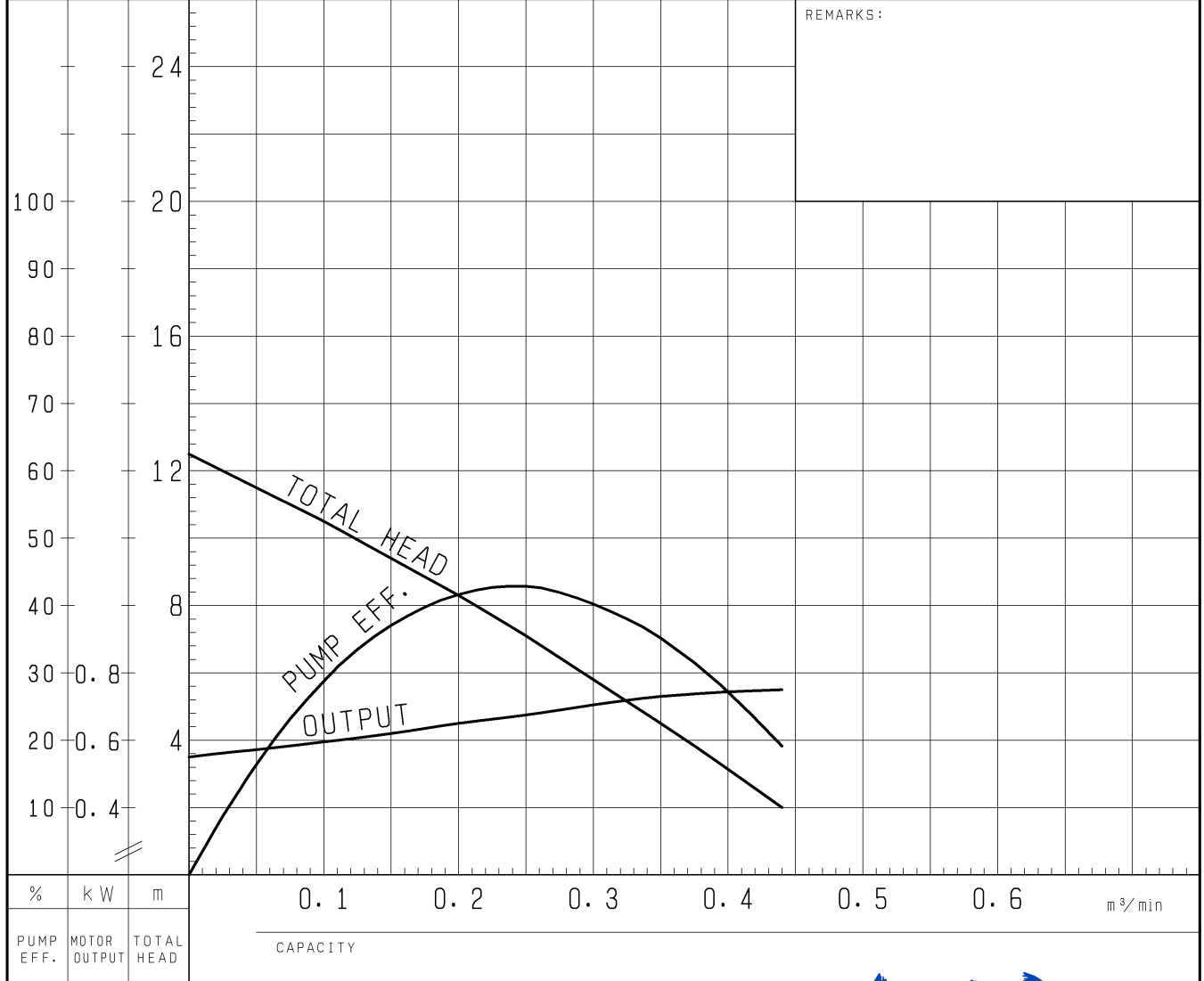

TSURUMI MFG. CO., LTD.

