

NO. A-14662-2

PUMP PERFORMANCE CURVES

TYPE	Submersible Portable Dewatering Pump	MODEL	HS2.4S -53 HSZ2.4S -53	FREQUENCY	50 Hz
------	---	-------	---------------------------	-----------	-------

CUSTOMER'S NAME _____

EQUIPMENT TITLE _____ NO. _____

	STANDARD SPECIFICATIONS	REQUIRED SPECIFICATIONS
DISCHARGE BORE	50 mm	mm
TOTAL HEAD	8 m	m
CAPACITY	0.1 m ³ /min	m ³ /min
MOTOR OUTPUT	0.4 kW	kW
PHASE x VOLTAGE	1 ϕ x V	ϕ x V
CURRENT	A	A
POLES / REVOLUTION	2 P / S. S. 3000 min ⁻¹	P / min ⁻¹
STARTING METHOD	CAPACITOR MOTOR	
INSULATION CLASS	E	

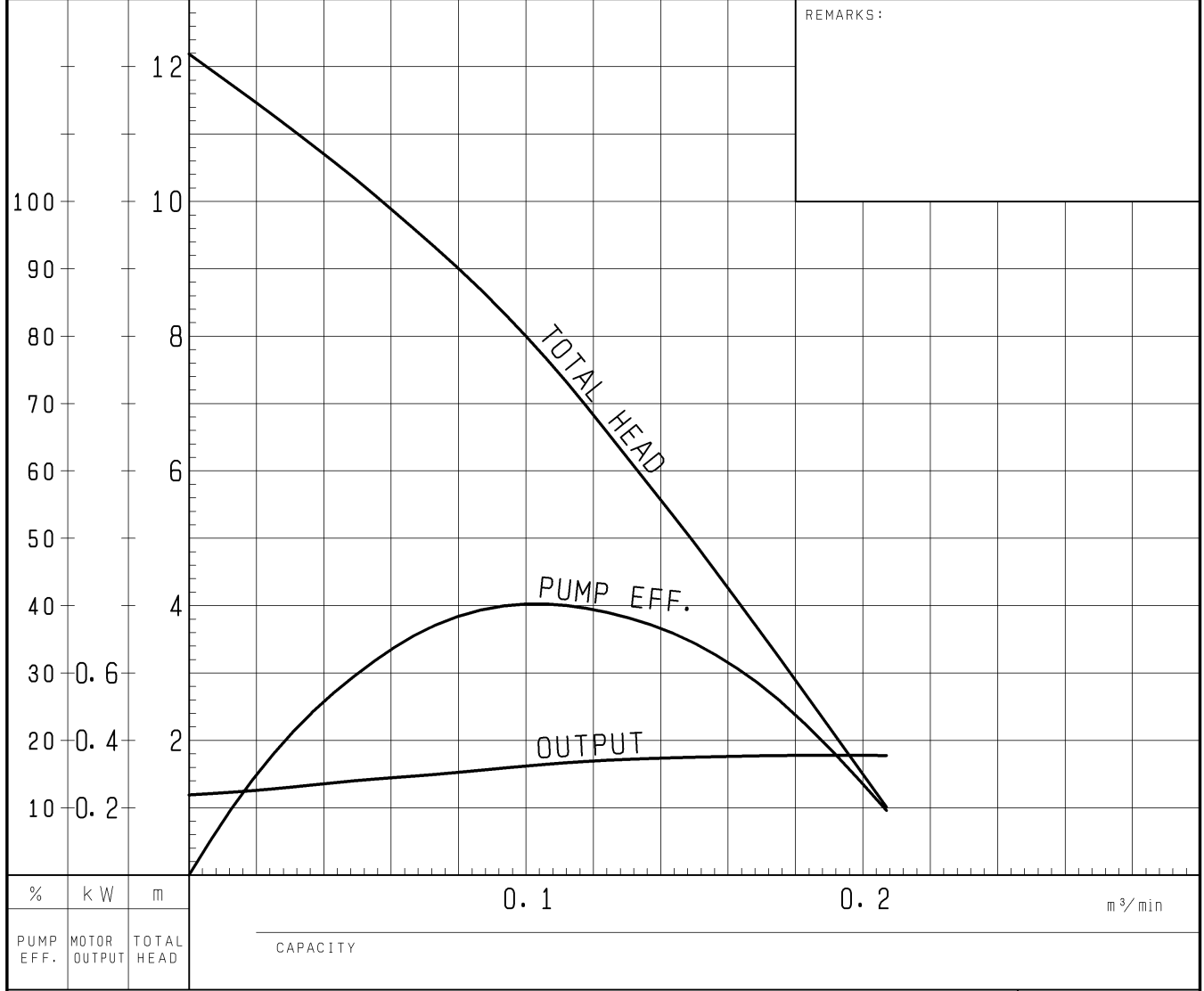

TSURUMI MFG. CO., LTD.

DIMENSION DRAWING		No.	No. A-14664-2
TYPE	Submersible Portable Dewatering Pump (Automatic)	MODEL	HSZ2.4S -53/63

Approximate Weight (※)
11.3kg
※excluding cable

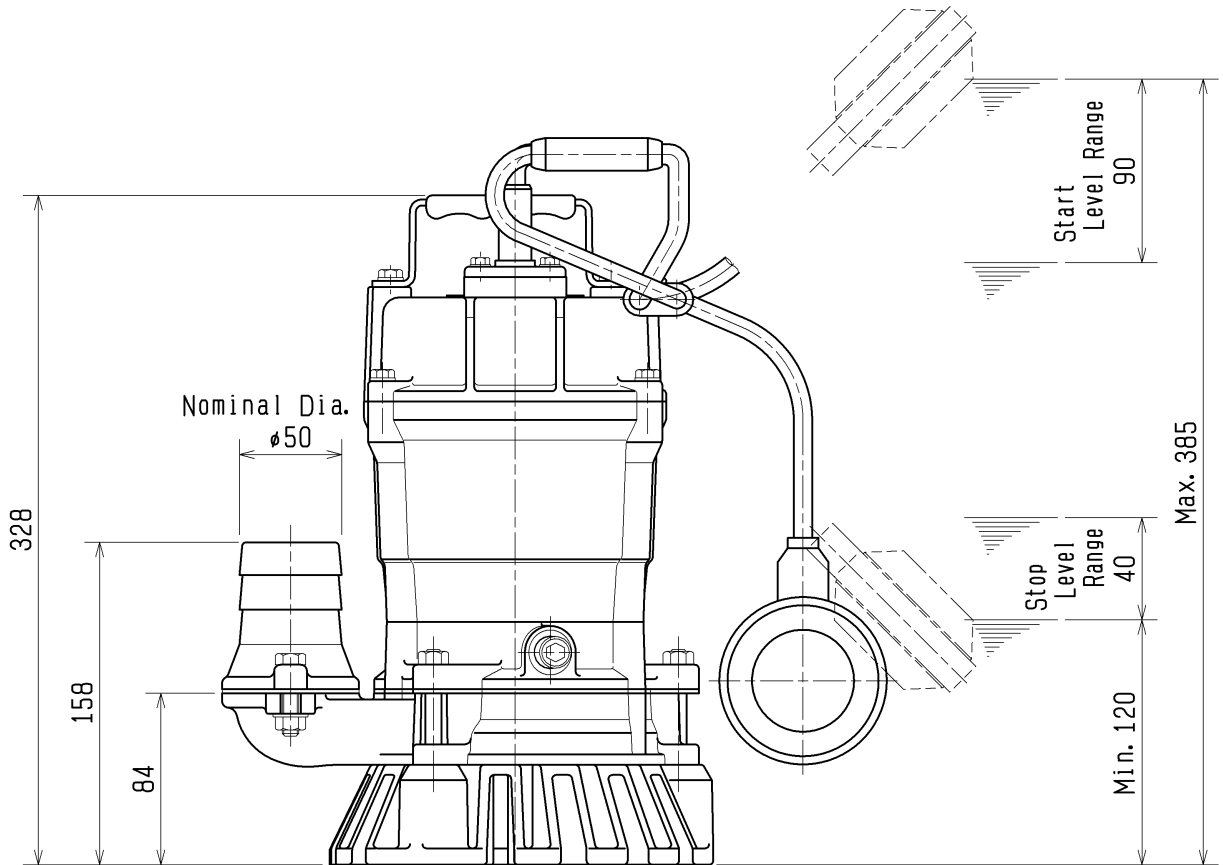
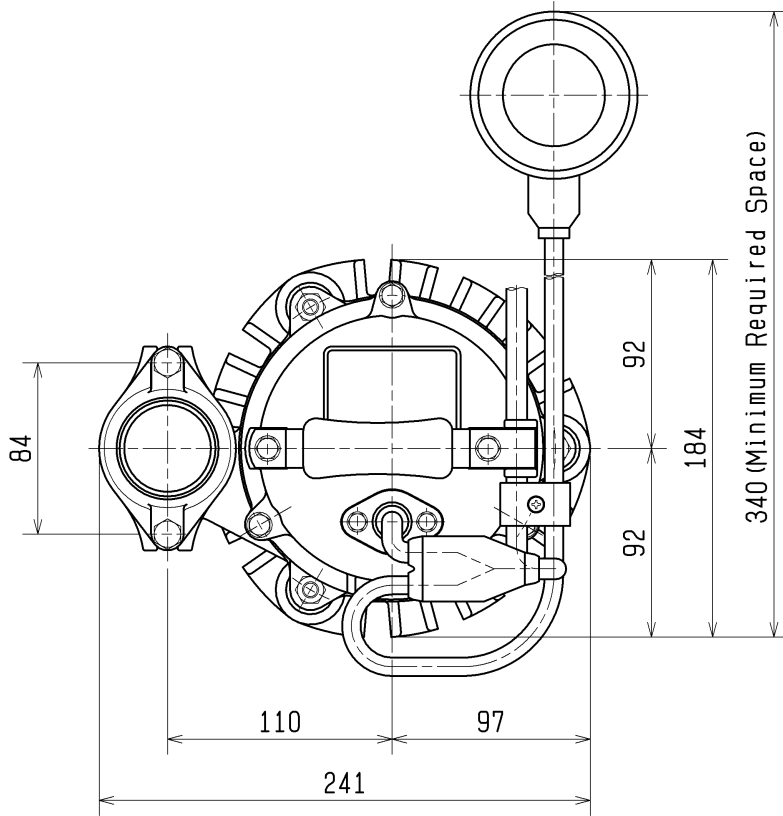

SECTIONAL DRAWING		No.	No. A-14665-5
TYPE	Submersible Portable Dewatering Pump (Automatic)	MODEL	HSZ2.4S -53/63

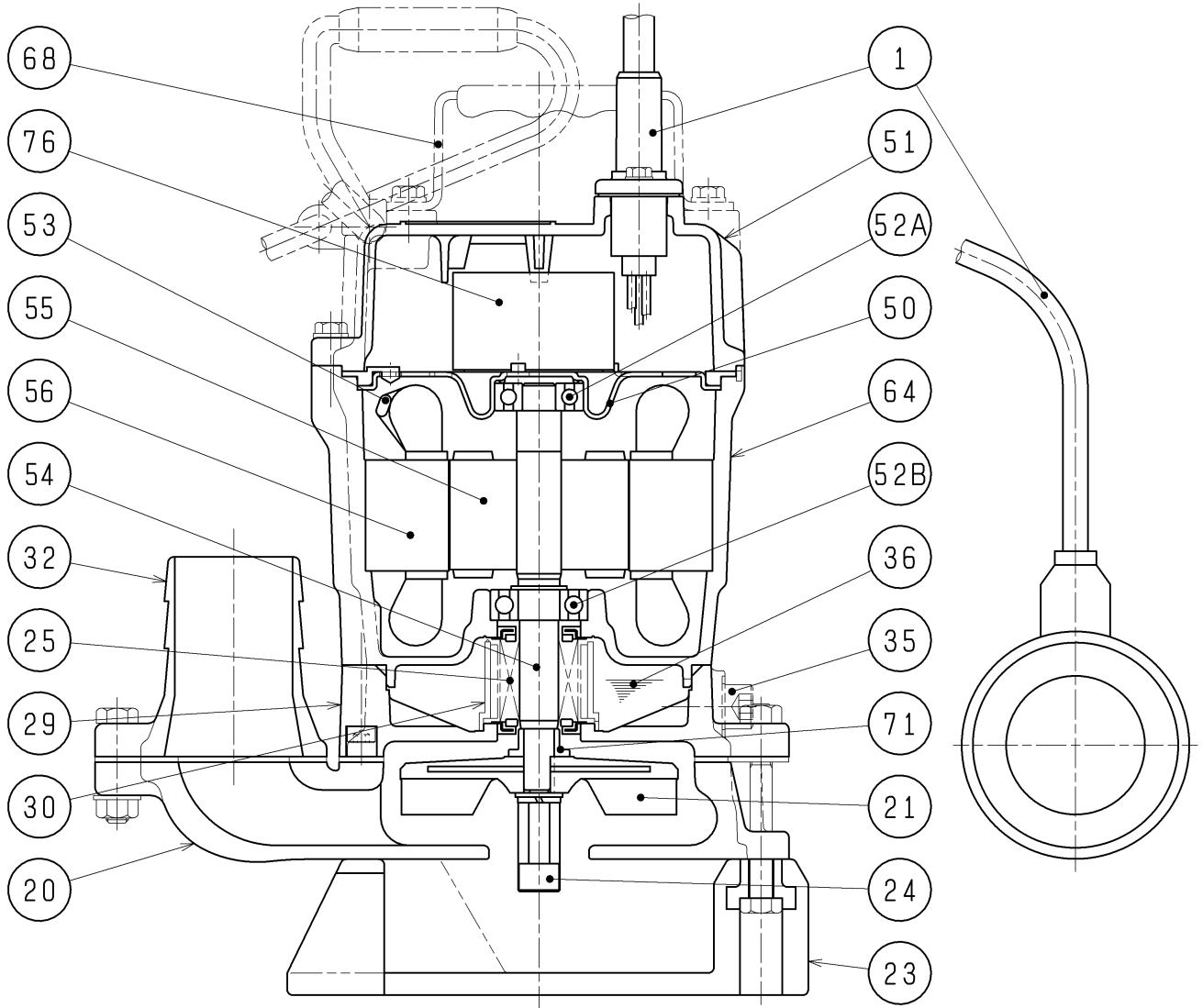

REQ. SPECIFICATION	

No.	DESCRIPTION	Q'TY	MATERIAL / NOTE	No.	DESCRIPTION	Q'TY	MATERIAL / NOTE
1	Cable c/w Float	1	PVC Sheath	52A	Upper Bearing	1	6201ZC3
20	Pump Casing	1	Gray Iron Casting	52B	Lower Bearing	1	6202ZC3
21	Impeller	1	Urethane Rubber	53	Motor Protector	1	
23	Strainer Stand	1	Vinyl Chloride	54	Shaft	1	Stainless Steel 403
24	Agitator	1	Sintered Alloy	55	Rotor	1	
25	Mechanical Seal	1	W-14VCA	56	Stator	1	
29	Oil Casing	1	Gray Iron Casting	64	Motor Frame	1	Aluminium Die Casting
30	Oil Lifter	1	Plastic	68	Handle	1	Steel Sheet & Natural Rubber
32	Hose Coupling	1	Aluminium Die Casting	71	Shaft Sleeve	1	Stainless Steel 304
35	Oil Plug	1	Stainless Steel 304	76	Capacitor	1	
36	Lubricant		Turbine Oil (ISO VG32)				
50	Motor Bracket	1	Steel Sheet				
51	Motor Head Cover	1	Aluminium Die Casting				